

Mechanical Dimensions: Inches [mm]

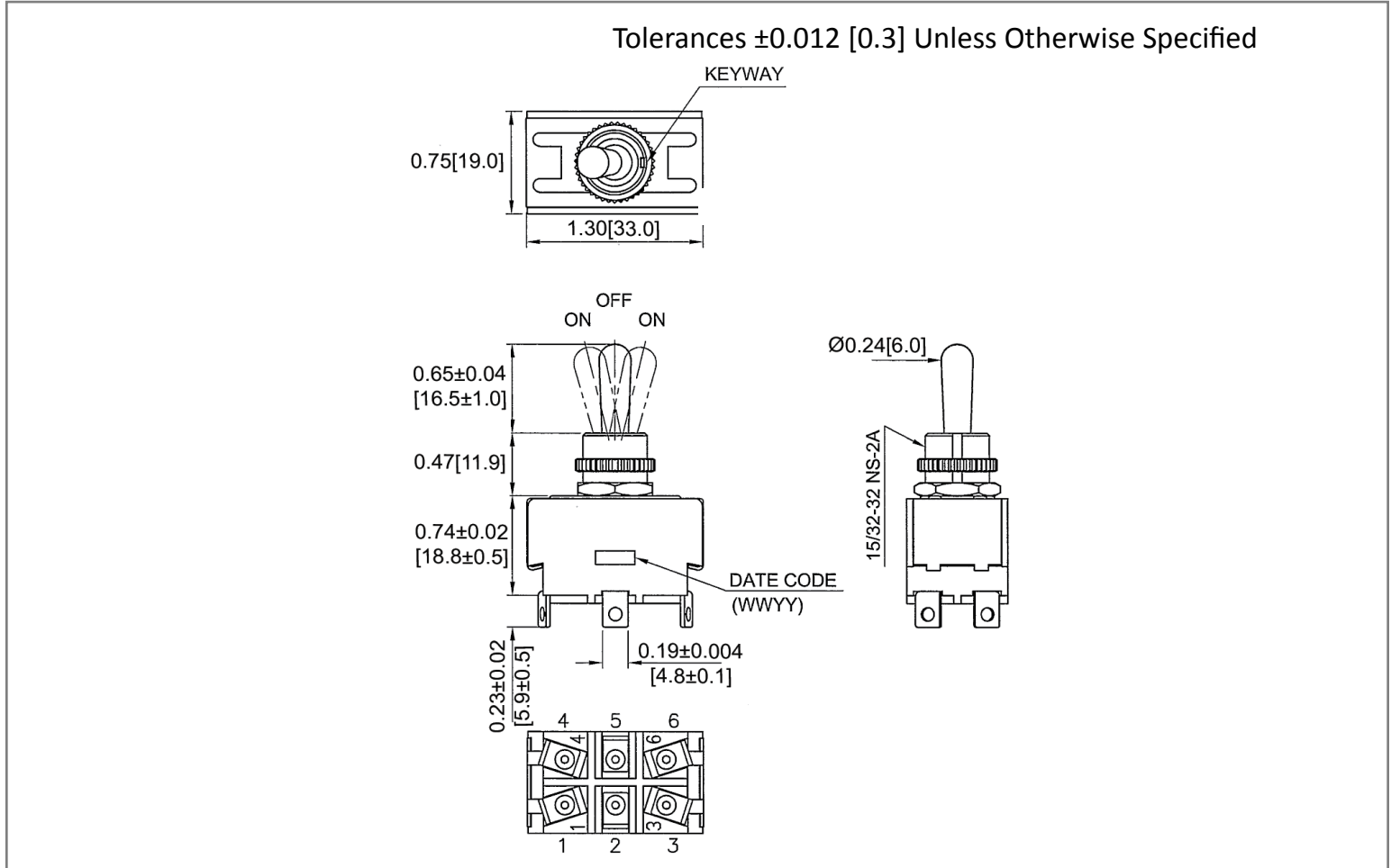

Mounting Hole

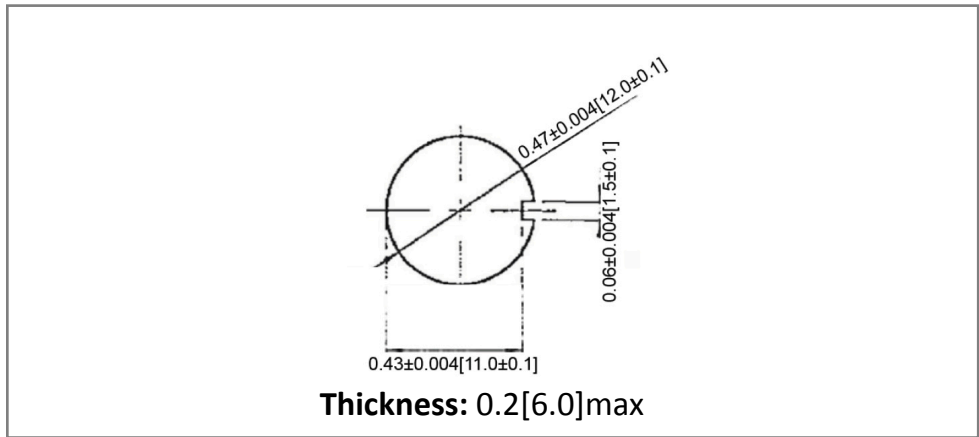

Circuit Diagram

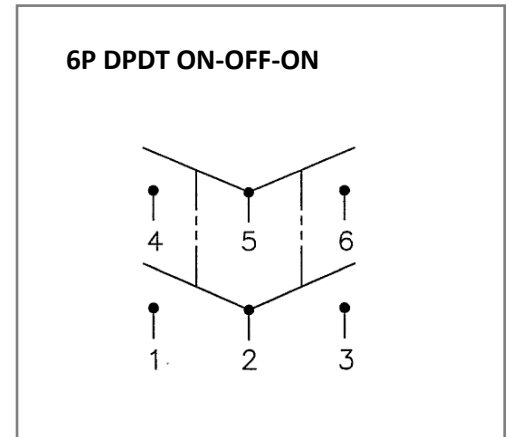

Electrical Specifications

DC Rating	21A 14V DC
AC Rating	20A 125V AC, 10A 277V AC, 1 1/2HP 125-250V AC 10(4)A 125/250V AC
Contact Resistance	50m ohm Max
Insulation Resistance	DC 500V 100M ohm Min
Dielectric Strength	AC 1500V 1 minute

Material Specifications

	1 Hex Nut Assy
	1 Knurl Nut Assy
Operation Temperature	1700gf±400gf
Ingress Protection (With WT2 Boot)	IPX6 (Above Mounted Panel Only)

Rev	Date of issue	Revision Notes	Designed	Approved
B	02-13-2020	Initial Drawing	RC	OF