

## Mechanical Dimensions: Inches [mm]

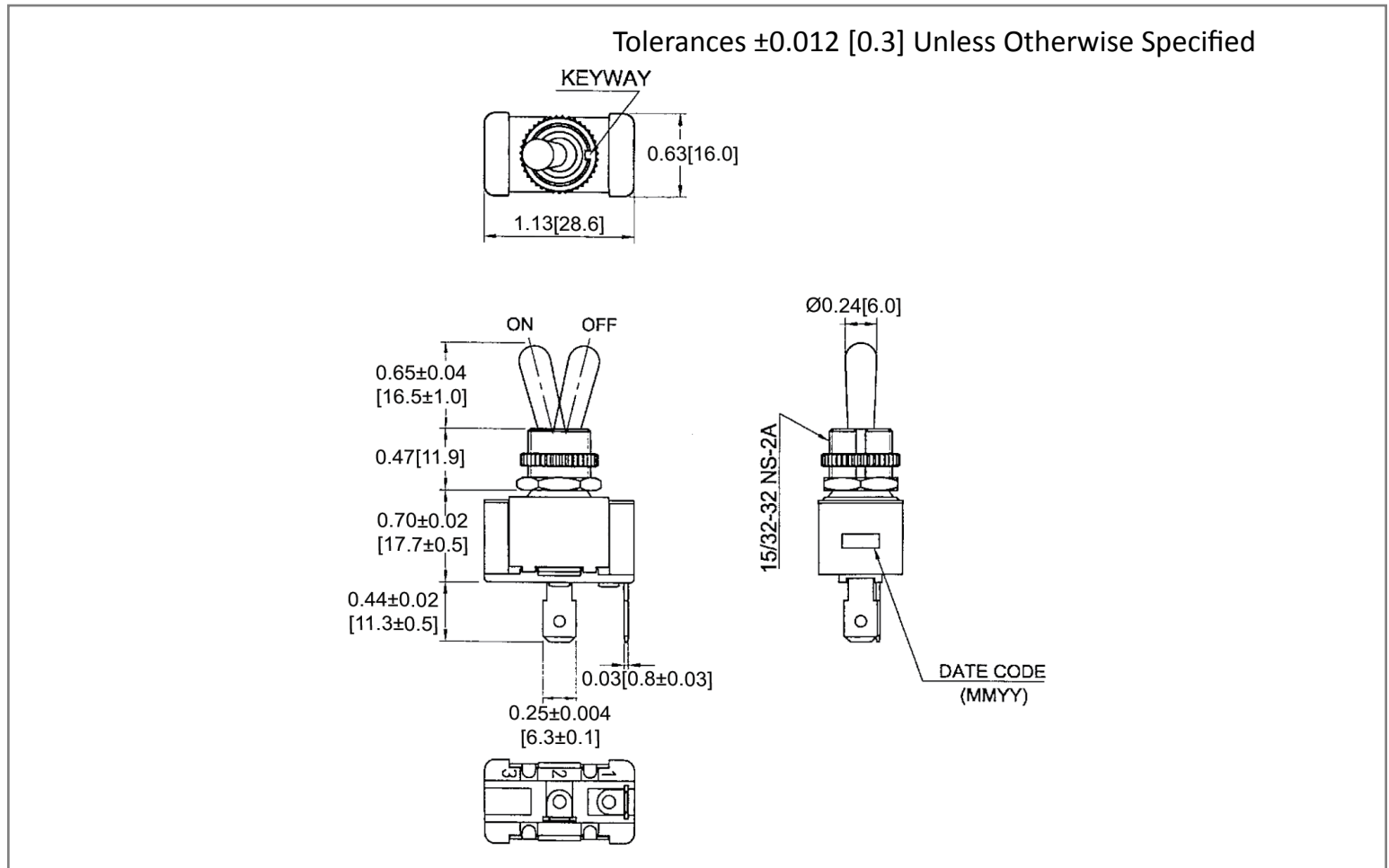

## Mounting Hole

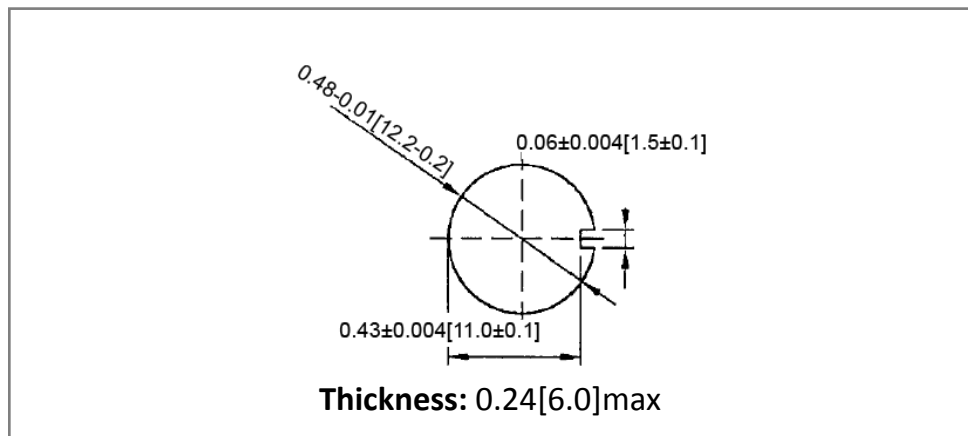

## Circuit Diagram

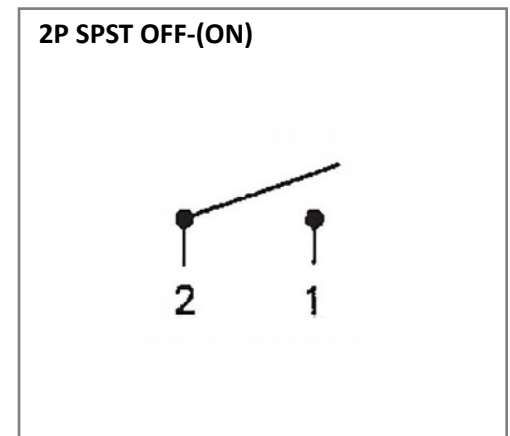

## Electrical Specifications

<b>DC Rating</b>	21A 14V DC
<b>AC Rating</b>	20A 125V AC, 10A 277V AC, 3/4HP 125-250V AC 12(4)A 125/250V AC
<b>Contact Resistance</b>	50m ohm Max
<b>Insulation Resistance</b>	DC 500V 100M ohm Min
<b>Dielectric Strength</b>	AC 1500V 1 minute

## Material Specifications

<b>Operation Force</b>	1100gf $\pm$ 400 gf
	1 Hex Nut Assy
	1 Knurl Nut Assy
<b>Operation Temperature</b>	-20°C ~ 85°C

**Rev      Date of issue      Revision Notes**

**Designed      Approved**

B	03-04-2020	Initial Drawing	RC	OF
---	------------	-----------------	----	----