

Mechanical Dimensions: Inches [mm]

Tolerances ± 0.012 [0.3] Unless Otherwise Specified

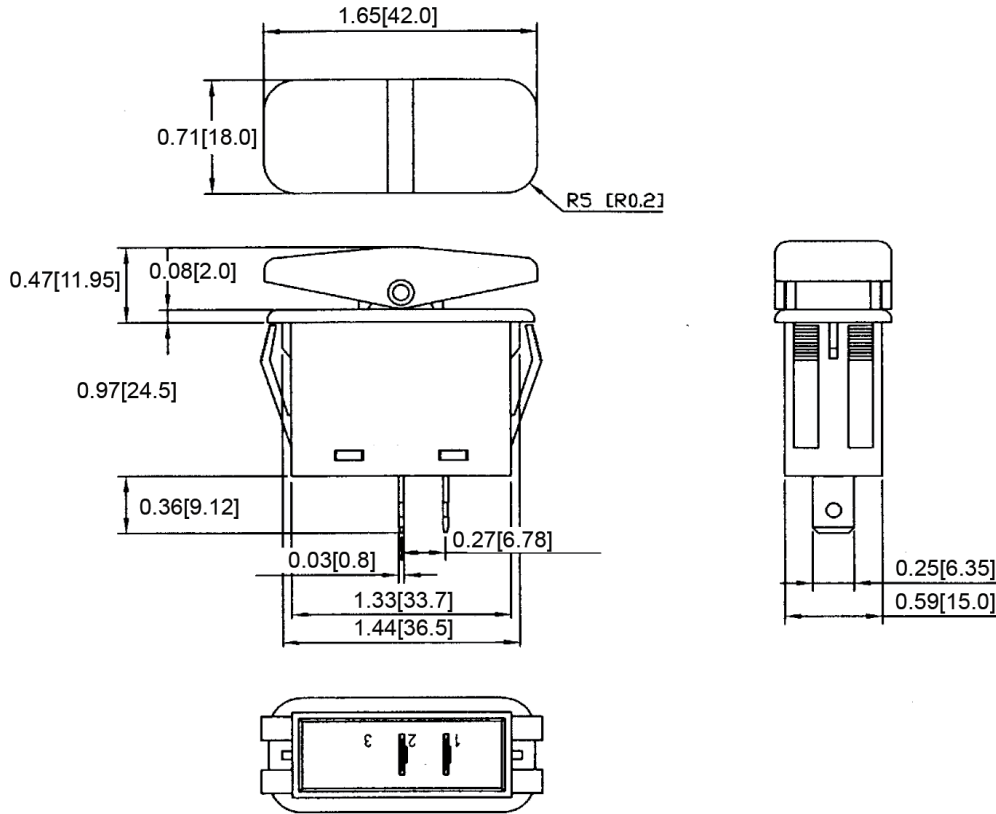

Mounting Hole

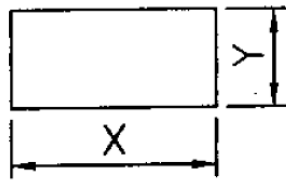

Thickness	X	Y
0.03~0.20 [0.75~5.0]	1.45+0.01 [36.8+0.2]	0.60+0.01 [15.3+0.2]

Circuit Diagram

2P SPST ON-(OFF)

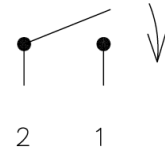

Electrical Specifications

DC Rating	20A 14V DC, 10A 24V DC
AC Rating	20A 125V AC, 10A 250V AC, 3/4HP 125-250V AC10(4)A 250V AC
Contact Resistance	50m ohm Max
Insulation Resistance	DC 500V 100M ohm Min
Dielectric Strength	AC 1500V 1minute

Material Specifications

Frame	Black, Nylon #66
Actuator	Black, Nylon 66+33%GF
Terminals	Copper alloy , Silver plated
Ingress Protection	IP56
Operation Temperature	-20°C~85°C

Rev	Date of issue	Revision Notes	Designed	Approved
B	02-26-2020	Initial Drawing	RC	OF