

Mechanical Dimensions: Inches [mm]

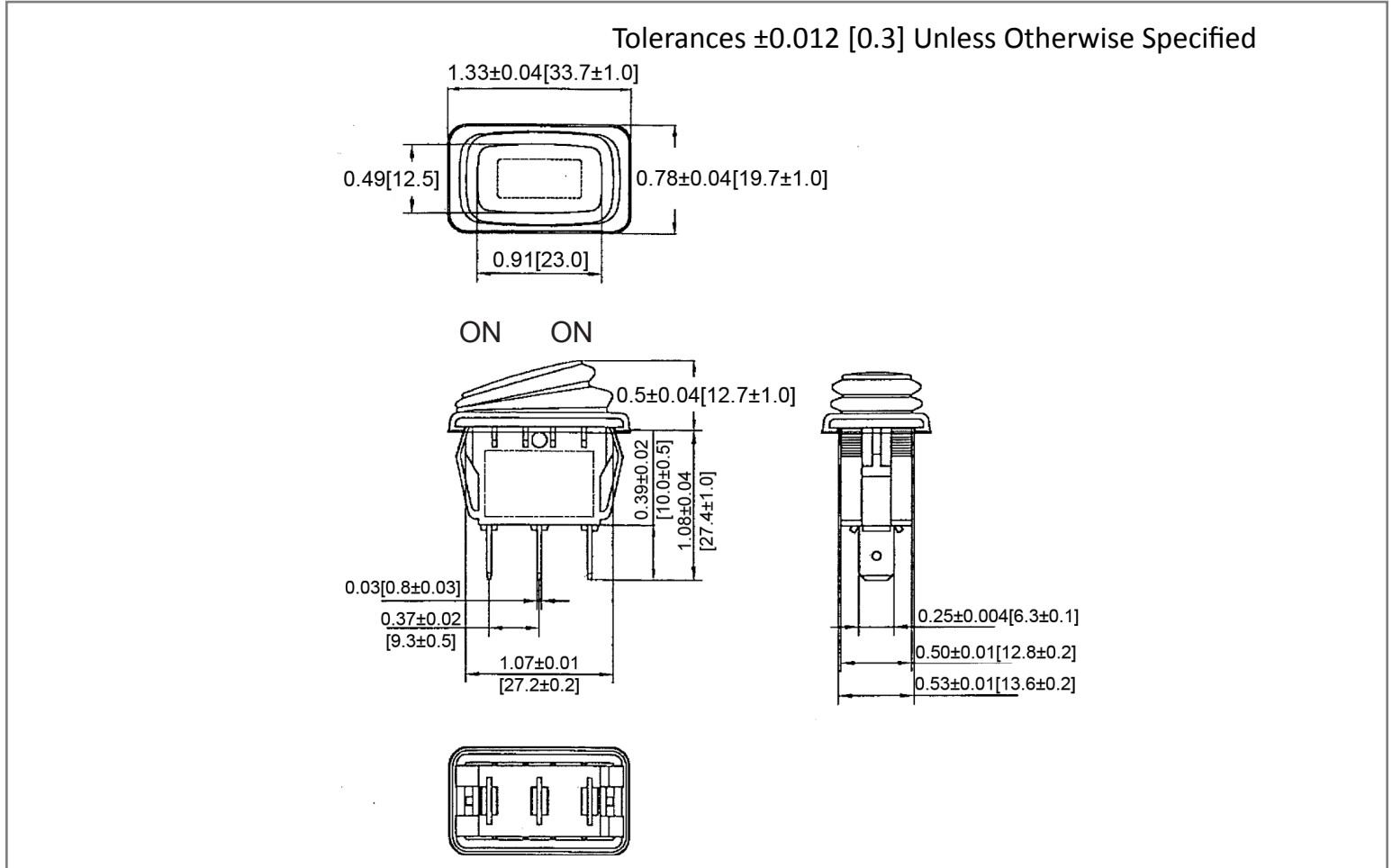

Mounting Hole

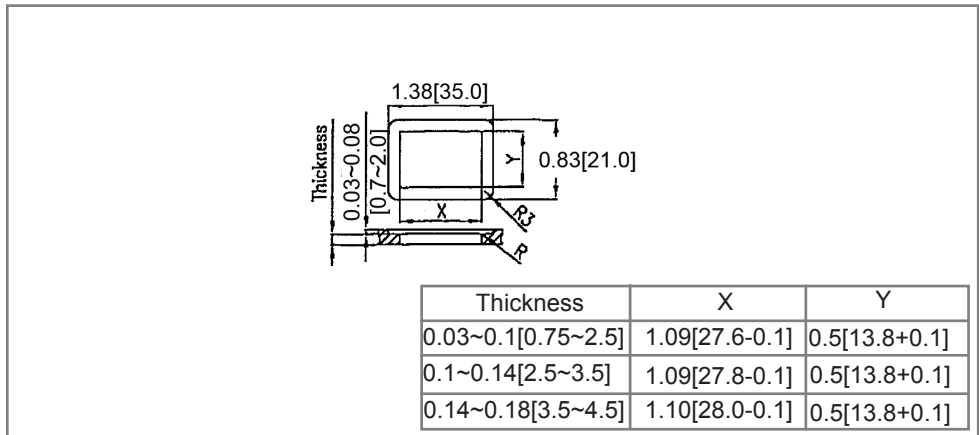

Circuit Diagram

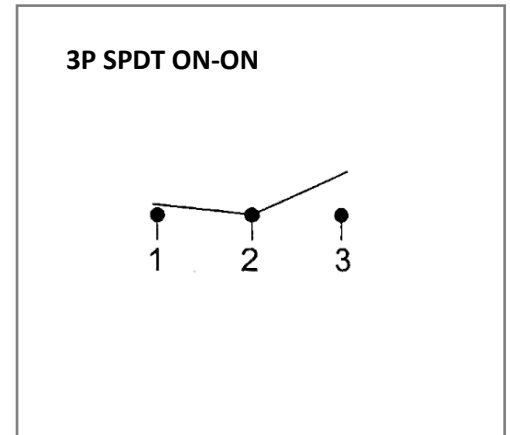

Electrical Specifications

DC Rating	16A 12V DC, 10A 28V DC	Frame	Black, Nylon 66
AC Rating	20A 125V AC 1/3HP, 16A 250V AC 1/2HP 16(4)A 125/250V AC	Actuator	Blue, Nylon#66+30%GF
Contact Resistance	50m ohm Max.	Ingress Protection	Black, Silicone IP65
Insulation Resistance	DC 500V 100M ohm Min.	Terminals	Silver Plated, Copper Alloy
Dielectric Strength	AC 1500V 1 minute	Operation Temperature	-25° C-85° C

Rev	Date of issue	Revision Notes	Designed	Approved
B	05-04-2020	Initial Drawing	RC	OF